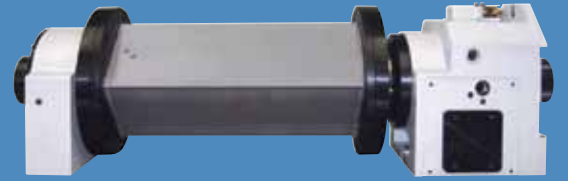
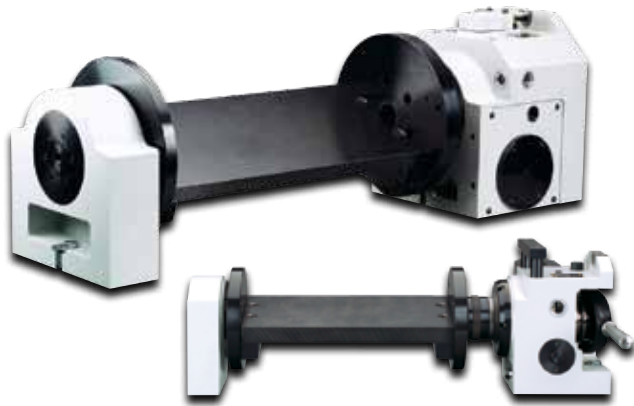

Plate and Cube Trunnion Accessories



Imagine the possibilities for multiple part processing...

- low-profile clamping
- window box fixturing for 4-sided machining
- toggle and saddle clamping
- collet blocks



Custom manufacturing available

Standard Features

- Bearing pillow block assures rigid, accurate positioning and will accommodate heavy loads
- Multiple part fixturing for increased output
- Load up a second plate to maximize cutting time
- All parts can be machined efficiently with the same tool before going to the next tool
- Plates provide two sides for fixturing, while the cube provides four sides
- 360° revolution depending on part clearance required
- Can be field installed to existing rotary units
- Plates are of blackened steel and the cube is of solid aluminum for ease of drilling and slotting according to the application requirements, either by Hardinge or by the customer
- One-inch pillow block riser included for use with DD300 rotary table indexer
- Custom manufacturing available

Optional Features

- Pillow block clamp available on PTA25 and CTA25 models with clamping torque of 275 ft-lb / 373 Nm
- Rotary union in pillow block for pneumatic fixturing on the cube trunnion – part number CJ 0002483CTA
- Complete line of collet blocks available for gripping round, hex, square and odd-shaped parts using collet sizes from 1C up to 35J

ROTARY DEVICE COMPATIBILITY	PT5C 5C PLATE	PTA25 A2-5 PLATE	CTA25 A2-5 PLATE
GD5C2	YES		
Centerline	4" (101.6)	NO	NO
Overall Length	23.80" (607)		
DD100	YES		
Centerline	4" (101.6)	NO	NO
Overall Length	28.82 (732)		
GD160LP	YES		
Centerline	5" (127.0)	NO	NO
Overall Length	23.48 (596)		
GD16C2		YES	YES
Centerline	NO	6" (152.4)	6" (152.4)
Overall Length		37.54" (954)	37.48" (952)
GD210LP		YES	YES
Centerline	NO	6" (152.4)	6" (152.4)
Overall Length		31.04" (788.3)	32.07" (814.7)
DD200		YES	YES
Centerline	NO	6" (152.4)	6" (152.4)
Overall Length		37.68 (957)	37.63 (956)
DD300		YES	YES
Centerline	NO	7" (177.8)	7" (177.8)
Overall Length		37.87 (962)	37.82 (961)

(millimeters in parentheses)



Hardinge Collet Blocks



PT5C2 Tilting Plate Trunnion for GD5C2, GD160LP and DD100 Rotary Units – Dimensions:

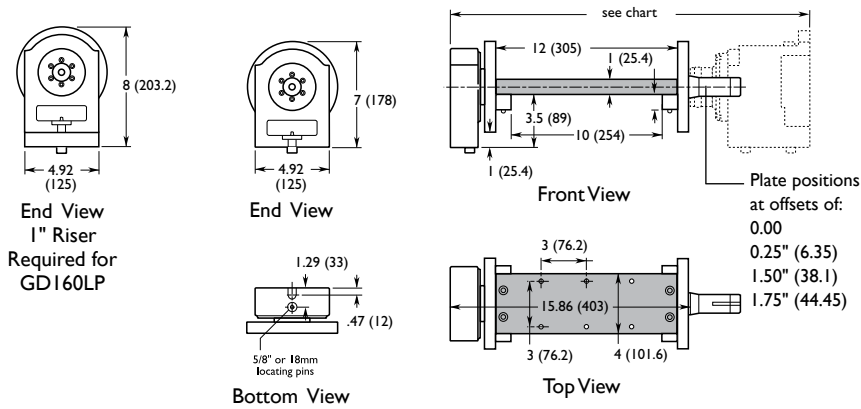

PTA25 Tilting Plate Trunnion for GD16C2, GD3J2, GD210LP, DD200 and DD300 Rotary Units – Dimensions:

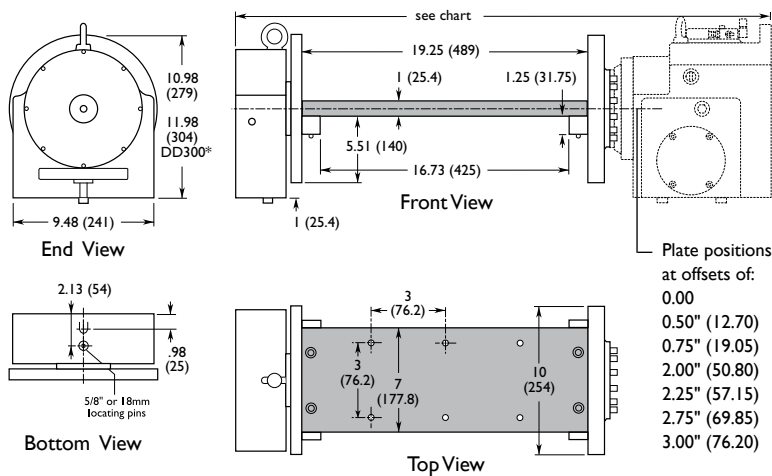

CTA25-4IN and CTA25-6IN Tilting Cube Trunnions for GD16C2, GD3J2, GD210LP, DD200 and DD300 Rotary Units – Dimensions:

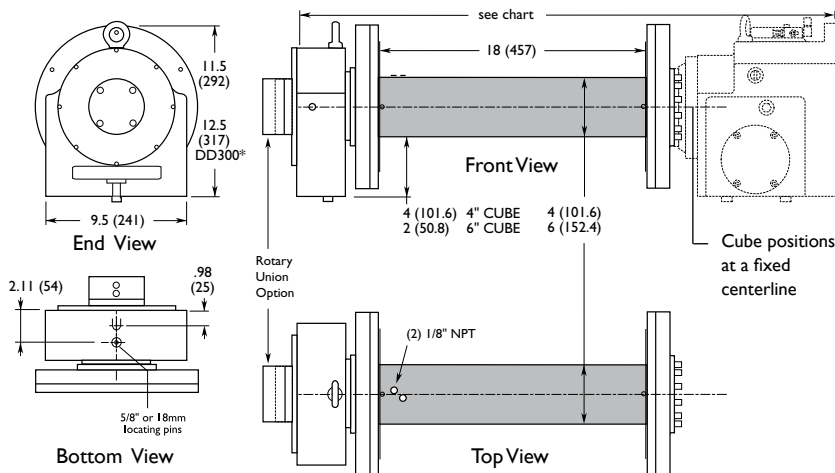

(millimeters in parentheses)

Plate Trunnion PT5C2

- 4 x 10" (101.6 x 254) machineable area on two surfaces
- Adjustable centerline to accommodate various part heights
- Collet-style face plate draws in to the 5C spindle nose of the rotary product
- 1" riser required for GD160LP

Plate Trunnion PTA25

- 7 x 16.73" (177.8 x 425) machineable area on two surfaces
- Adjustable centerline to accommodate various part heights
- Face plate bolts on to the A2-5 spindle nose of the rotary product
- 1" riser* required for DD300

Cube Trunnion CTA25

- 18" (457mm) long solid aluminum block for four-sided machining applications
- Available in 4" and 6" cubes
- 1/8" NPT ports to accommodate air-actuated workholding
- Face plate bolts on to the A2-5 spindle nose of the rotary product
- Can easily be configured for highly productive 2D work
- 1" riser* required for DD300



Hardinge Machine Tools Ltd.
 Whiteacres,
 Cambridge Road,
 Whetstone, Leics.
 LE8 6BD
 Tel : +44 (0)116 2869900
 Fax : +44 (0)116 2869901
 Order Online: www.shophardinge.co.uk
 E-mail: sales@hardinge.co.uk

All specifications are subject to change without notice due to ongoing continuous improvement. All marks indicated by © and ™ are trademarks of Hardinge Inc.
 © 2012 Hardinge Inc.